

FLAP DRIVER D722 NOTES

U6, PIN 4 IS CAMERA SAFE=0 BEFORE TIME DELAY WHEN:
DAY; FLAP CLOSED
NIGHT; FLAP CLOSED
NIGHT; FLAP COMPLETELY OPEN

U6, PIN 4 IS UNSAFE=1 WHEN:
DAY; FLAP COMPLETELY OPEN
DAY OR NIGHT; FLAP PARTIALLY OPEN
DAY OR NIGHT; FLAP CLOSE AND FLAP OPEN SWITCHES ARE
SIMULTANEOUSLY ARE "0"

MOTOR

MOTOR CURRENT IS APPROXIMATELY 25MA WHILE FLAP IS IN MOTION
MOTOR STALL CURRENT IS 1.1A AT 12.5V
MOTOR STALL CURRENT LIMITED TO 100MA ON FC BOARD AND TURNS
MOTOR POWER OFF UNTIL MANUALLY RESET WITH PUSHBUTTON.
CHECK FLAP FOR OBSTRUCTION BEFORE RESETTING OR DAMAGE
TO GEAR TRAIN MAY RESULT

320MS DELAY

WHEN CHANGING DIRECTION WHILE IN MOTION A 100MS CURRENT SPIKE
OCCURS. DELAY ADDED SO OVER CURRENT DETECTOR WILL NOT SHUT
MOTOR OFF

ANTENNA CANNOT MOVE

UNSAFE

FLAP DRIVER BOARD NOT INSTALLED

12V BATT. GND INSTALLED AT J1-R. THE DRIVE CONTACTOR
CONTROL RELAY RETURNS TO CONTROL BOX PWR SUPPLY COMMON
COMES ONTO THIS BOARD ON J1-1, J1-22, J1-A, J1-Z. THE
12V BATT. GND. AND PWR SUPPLY COMMON ARE CONNECTED
THROUGH BOARD. JUMPER TB10-14 TO PWR SUPPLY COMMON TO
ENABLE ANTENNA MOVEMENT.

CAMERA FLAP SYSTEM

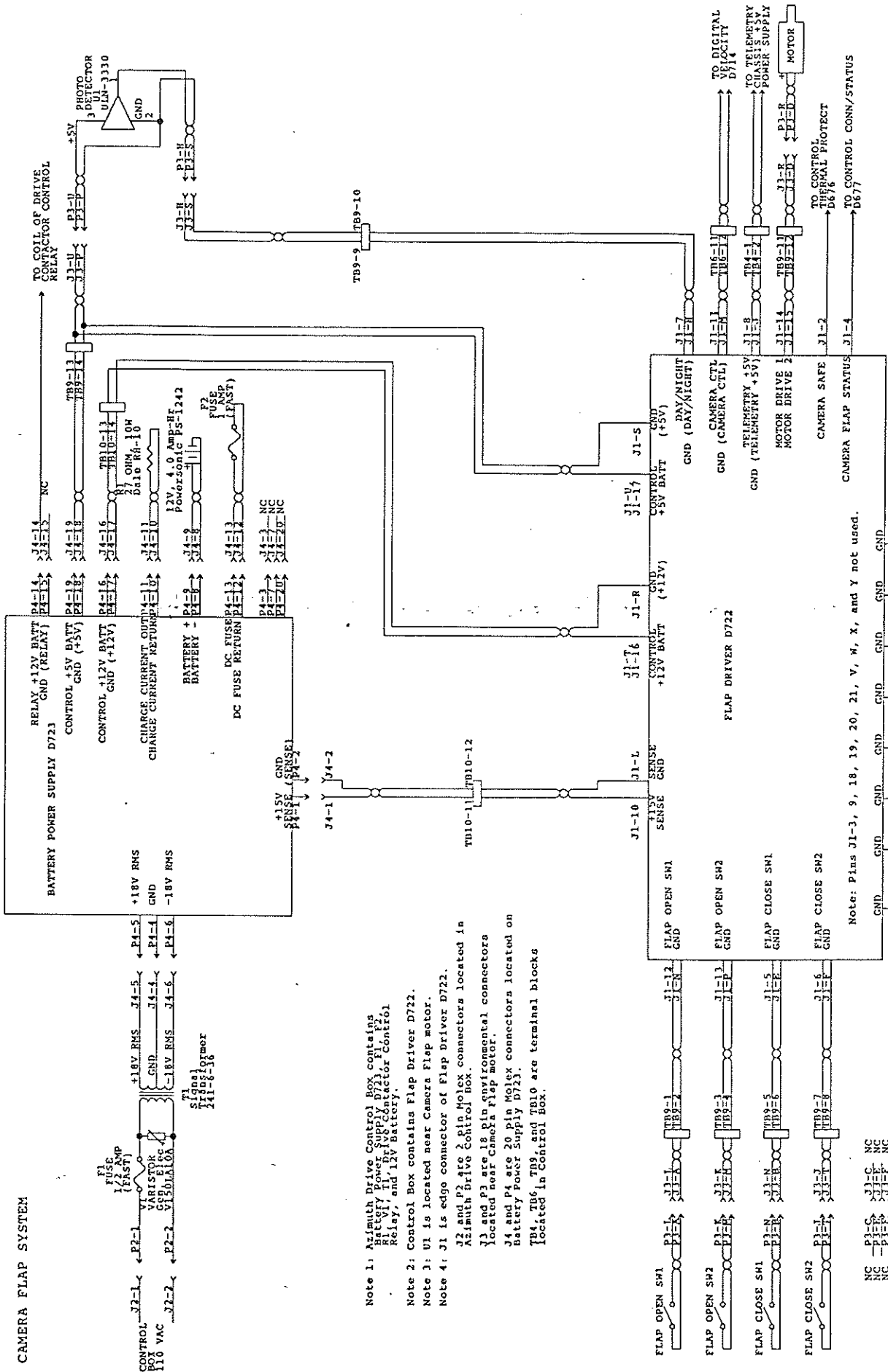

- Note 1: Azimuth Drive Control Box contains Battery Power Supply D723, Relay, Control Box, and 12V Battery.
- Note 2: Control Box contains Flap Driver D722.
- Note 3: U1 is located near Camera Flap motor.
- Note 4: J1 is edge connector of Flap Driver D722.
- J2 and J3 are 2 pin Molex connectors located in Azimuth Drive Control Box.
- J3 and J4 are 18 pin cylindrical connectors located near Camera Flap motor.
- J4 and P4 are 20 pin Molex connectors located on Battery Power Supply D723.
- TB9, TB6, TB9, and TB10 are terminal blocks located in Control Box.

Note: Pins J1-3, 9, 18, 19, 20, 21, V, M, X, and Y not used.

NC	P1-C	NC
NC	P1-E	NC
NC	P1-F	NC
NC	P1-G	NC
NC	P1-H	NC
NC	P1-I	NC
NC	P1-J	NC
NC	P1-K	NC
J1-1	J1-22	J1-A
J1-1	J1-A	J1-B
J1-1	J1-B	J1-C
J1-1	J1-C	J1-D
J1-1	J1-D	J1-E
J1-1	J1-E	J1-F
J1-1	J1-F	J1-G
J1-1	J1-G	J1-H
J1-1	J1-H	J1-I
J1-1	J1-I	J1-J
J1-1	J1-J	J1-K
J1-1	J1-K	J1-L
J1-1	J1-L	J1-M
J1-1	J1-M	J1-N
J1-1	J1-N	J1-O
J1-1	J1-O	J1-P
J1-1	J1-P	J1-Q
J1-1	J1-Q	J1-R
J1-1	J1-R	J1-S
J1-1	J1-S	J1-T
J1-1	J1-T	J1-U
J1-1	J1-U	J1-V
J1-1	J1-V	J1-W
J1-1	J1-W	J1-X
J1-1	J1-X	J1-Y
J1-1	J1-Y	J1-Z

FLAP DRIVER D722

NOTE 2: CHANGING DIRECTION OF MOTOR RESULTS IN A LARGE 100MS MOTOR CURRENT SPIKE. ADD R4, C14 TIME DELAY SO THAT MOTOR STALL DETECT CIRCUIT WILL NOT TRIP DURING SPIKE.

POSITIVE PULSE GENERATED ON EVERY TRANSITION AT U9, PIN 6 WILL RETRIGGER 41 SECOND TIMER (U7A)

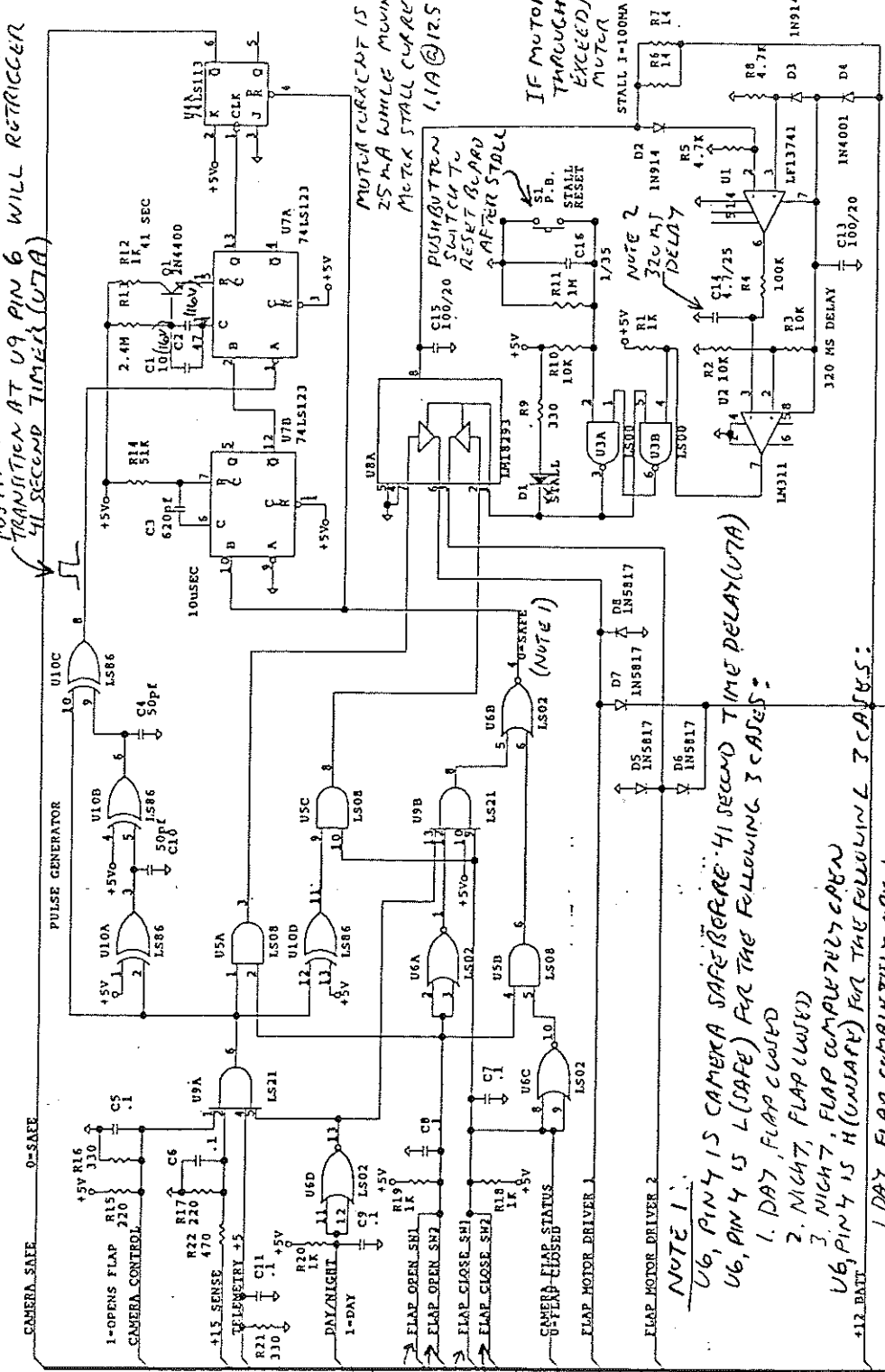

MOTOR CURRENT IS APPROX. 25 MA WHILE MOVING FLAP. MOTOR STALL CURRENT IS 1.1A @ 12.5V.

IF MOTOR CURRENT EXCEEDS 100 MA, MOTOR STALL DETECT CIRCUIT WILL TURN OFF POWER TO MOTOR AND TURN ON LED.

NOTE 1: U6, PIN 4 IS CAMERA SAFETY (SAFE) FOR THE FOLLOWING 3 CASES:
 U6, PIN 4 IS L (SAFE) FOR THE FOLLOWING 3 CASES:
 U6, PIN 4 IS H (UNSAFE) FOR THE FOLLOWING 3 CASES:

1. DAY, FLAP CLOSED
 2. NIGHT, FLAP (UNSAFE)
 3. NIGHT, FLAP COMPLETELY OPEN
1. DAY, FLAP COMPLETELY OPEN
 2. DAY OR NIGHT, FLAP PARTIALLY OPEN
 3. DAY OR NIGHT, FLAP COMPLETELY OPEN
1. DAY OR NIGHT, FLAP COMPLETELY OPEN
 2. DAY OR NIGHT, FLAP COMPLETELY OPEN
 3. DAY OR NIGHT, FLAP COMPLETELY OPEN

A	+	12 BATT
B	+	5V BATT
C	NC	
D	NC	
E	NC	
F	NC	
G	NC	
H	NC	
I	NC	
J	NC	
K	NC	
L	NC	
M	NC	
N	NC	
O	NC	
P	NC	
Q	NC	
R	NC	
S	NC	
T	NC	
U	+	5V
V	+	5V
W	+	5V
X	+	5V
Y	+	5V
Z	+	5V
1	+	5V
2	+	5V
3	+	5V
4	+	5V
5	+	5V
6	+	5V
7	+	5V
8	+	5V
9	+	5V
10	+	5V
11	+	5V
12	+	5V
13	+	5V
14	+	5V
15	+	5V
16	+	5V
17	+	5V
18	+	5V
19	+	5V
20	+	5V
21	+	5V
22	+	5V

U.C. BERKELEY
 E.A.L.L.
 TITLE: FLAP DRIVER
 SIZE: Document Number D722
 REV: APRIL 5, 1971