

50 MHz Receiver

Kosh Yokota, Dick Plambeck, 1/9/2004

Version 2, 10/15/2004, includes test results

Version 3, 8/3/2005, caution about no buffer amp on monitor output

Function: receives 50 MHz phaselock reference signal at the antenna, sent from the lobe rotator in the lab via singlemode fiber.

Brief circuit description: The optical signal is received by a JDS Uniphase EDR512C photodiode with integrated transimpedance amplifier. The RF output is amplified, passed through a 50 MHz low pass filter (to eliminate 100 MHz and higher harmonics), and split to provide 4 outputs, each +8 dBm.

Input:

- 1310 nm optical (from LED) signal on singlemode fiber, FC-APC connector. The expected optical intensity (allowing for 3 dB loss in fiber) is -17 dBm (20 uW). The acceptable input level is -21 dBm or greater. The circuit functions down to an input level of -27 dBm or less, but the noise increases.

Output:

- Four SMA female connectors with the 50 MHz reference signal, +8 dBm nominal. Output power ranges from about +7 dBm to +9.5 dBm over the likely range of optical input powers.

Indicator LED:

- Optical power: green for > -21 dBm (acceptable operation)
yellow for -27 dBm $<$ pwr $<$ -21 dBm (marginal operation)
off for pwr $<$ -27 dBm

Power supply/monitor through 9-pin D-subminiature connector, male:

1	-15 V, 25 mA
2	NC
3	pwr GND
4	gnd for photocurrent monitor
5	+15 V, 250 mA
6	NC
7	photocurrent OK: 0=no, 1=yes (superfluous indicator)
8	photocurrent monitor, 10V/mA; expected level is 0.2 V
9	NC

Known problems: (1) A few units have oscillated at low frequency (0-50 MHz); pasting absorber under the lid fixes the problem. (2) The photocurrent monitor output, pin 8 on D connector, is connected directly to the input of the LED circuit – hence ground loops or noise on pin 8 can turn on green LED even if there is no optical pwr in.

Test fixture: 50 MHz from synthesizer is fed to circuit below. Current through laser is approximately 40 mA, optical power output is approx -14 dBm. Note that a non-APC fiber connector must be used on the transmitter! For test purposes, optical power to receiver can be adjusted by pulling fiberoptic connector part way out of mating sleeve.

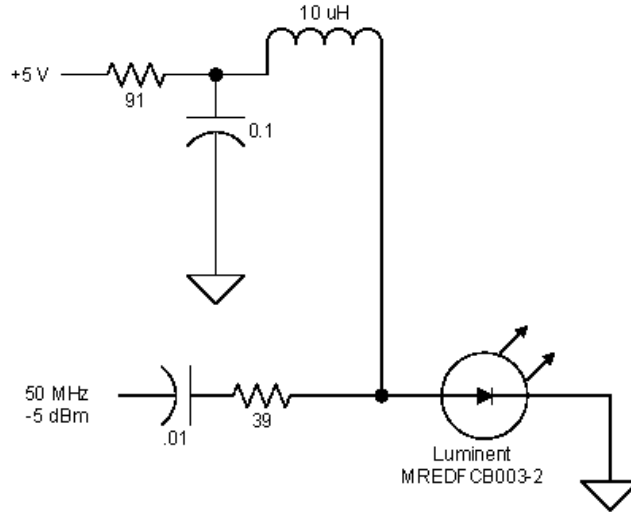

Test results (50 MHz rcvr #1, tested 10/15/04; absorber pasted inside lid): With -20 dBm optical power into receiver (photocurrent monitor = 0.25 V, LED is green), the signal to noise ratio of the 50 MHz tone is roughly 500, which corresponds to an rms phase error of 0.03 radians.

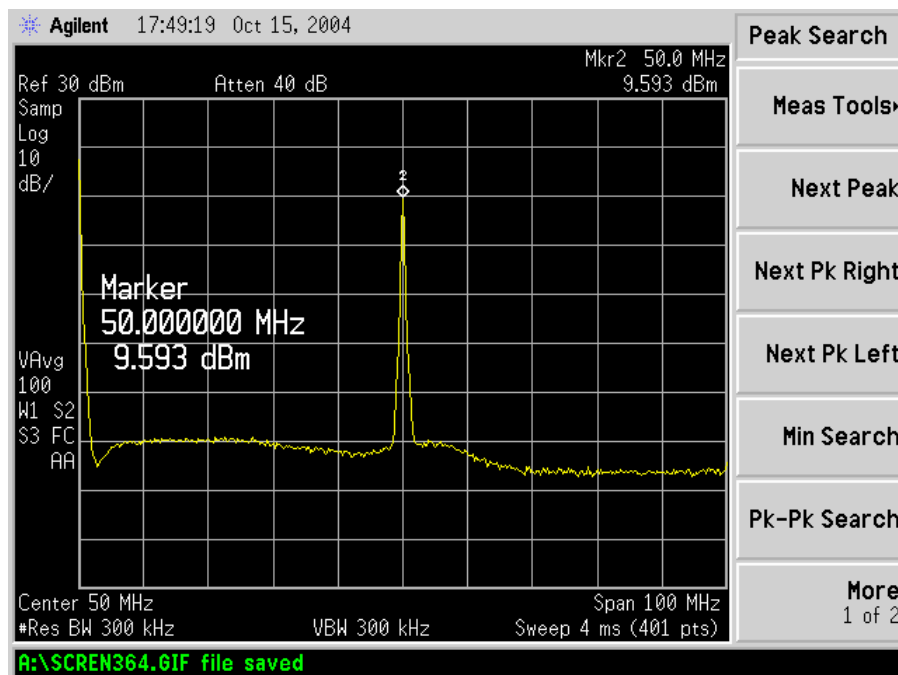

For -25 dBm optical power input (photodiode current = 0.1 V, LED is yellow), the signal to noise ratio is still approximately 200. This corresponds to an rms phase error of 0.05 radians, which leads to negligible decorrelation.

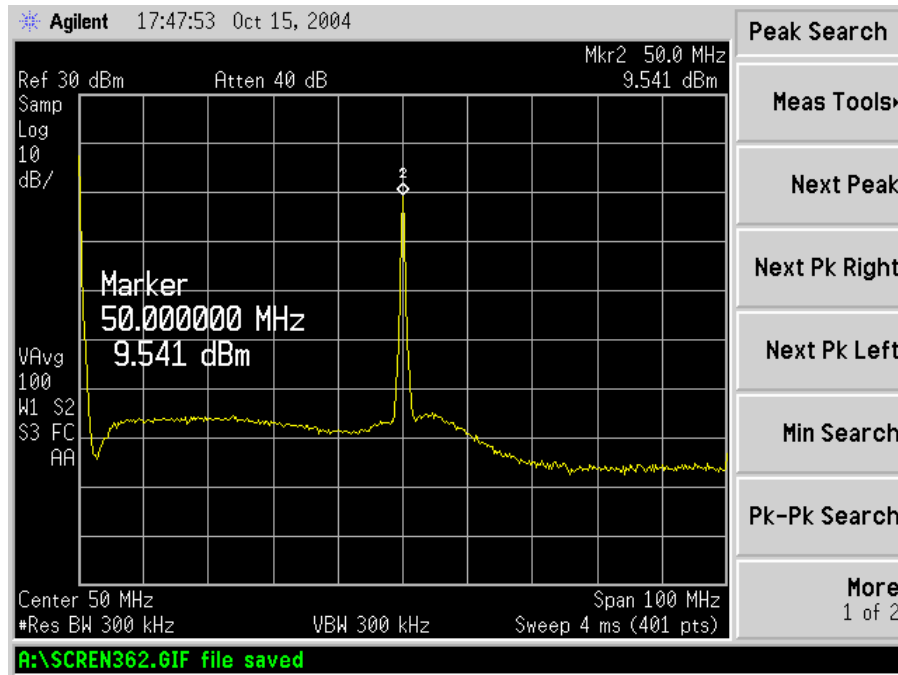

Harmonics: At the highest likely optical power level (-15 dBm; photodiode current monitor = 0.8 V), the 2nd and 3rd harmonics are still more than 50 dB below the peak:

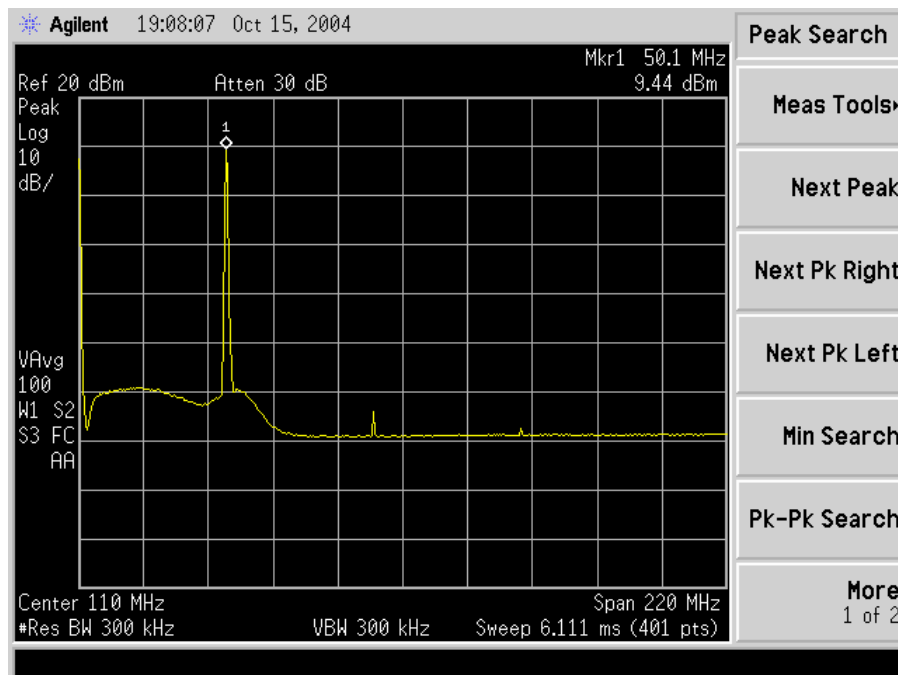

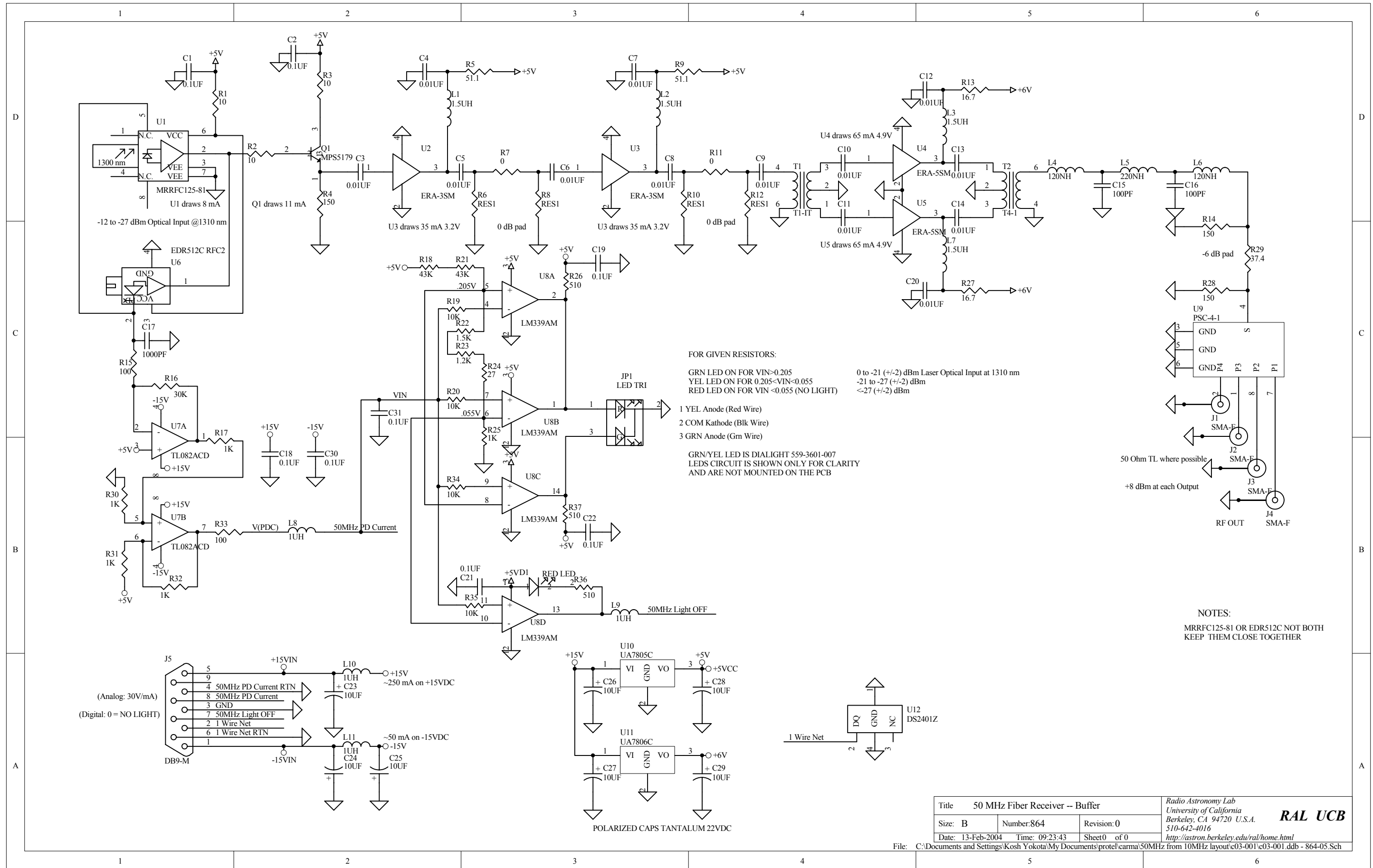

Title 50 MHz Fiber Receiver -- Buffer			Radio Astronomy Lab University of California Berkeley, CA 94720 U.S.A. 510-642-4016 http://astron.berkeley.edu/ral/home.html	
Size: B	Number: 864	Revision: 0	RAL UCB	
Date: 13-Feb-2004	Time: 09:23:43	Sheet 0 of 0		

50 MHz Rcvr Outline,
 Rev B
 5 Jan 04, Dick Plambeck

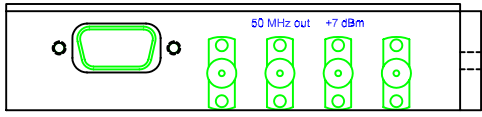
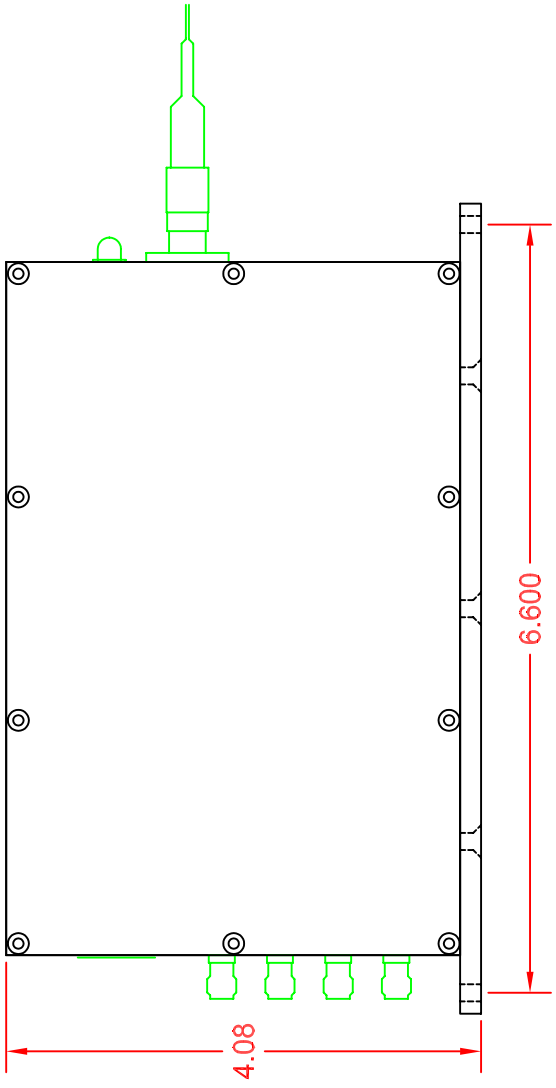
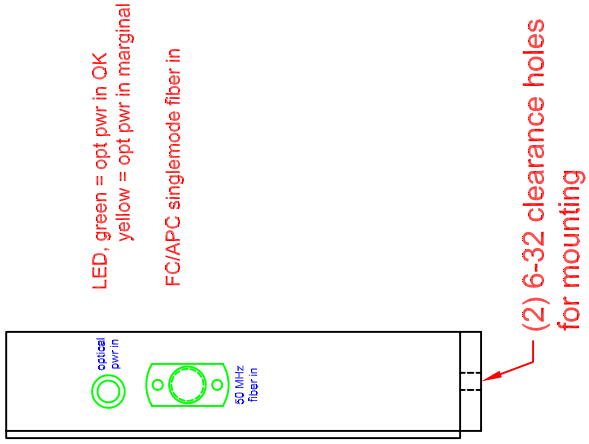
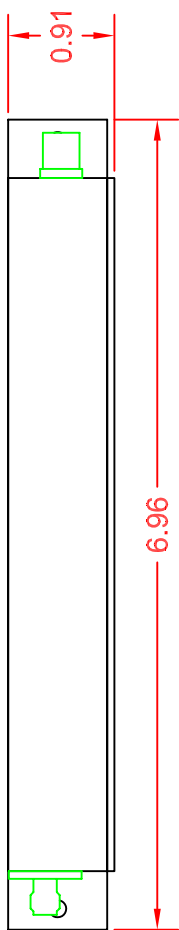

9-pin D male power in, monitor out
 (4) SMA female, 50 MHz out, +7 dBm